

ECOPRO

TANKLESS WATER HEATERS

INSTALLATION INSTRUCTIONS & HOME OWNERS MANUAL

| E11 | E13 | E18 | E27 |

IMPORTANT SAFETY INFORMATION

When installing or using any high voltage electrical appliance, basic safety precautions should always be followed. Under no circumstance should you attempt to clean, install, inspect, repair, disassemble or otherwise service this water heater, without first shutting off **all** power to the unit directly at the circuit breaker box. **SERIOUS BODILY INJURY OR DEATH COULD OCCUR IF YOU IGNORE THIS WARNING.**

THIS PRODUCT SHOULD BE INSTALLED BY A QUALIFIED ELECTRICIAN AND A QUALIFIED PLUMBER IN ACCORDANCE WITH ALL NATIONAL, STATE, PROVINCIAL AND LOCAL ELECTRICAL & PLUMBING CODES.

PLEASE READ THESE INSTRUCTIONS THOROUGHLY AND COMPLETELY PRIOR TO INSTALLATION & USE. FAILURE TO DO SO COULD CAUSE PROPERTY DAMAGE, SERIOUS INJURY, OR DEATH.

This manual should be given to the homeowner after installation and should be retained for future reference.

IMPORTANT SAFETY INFORMATION

READ ALL INSTRUCTIONS BEFORE USING



DANGER!

WATER TEMPERATURE SAFETY SETTING

Safety and energy conservation are factors to be considered when selecting the water temperature setting of water heater's thermostat. Water temperatures above the 125°F can cause severe burns or death from scalding. Be sure to read and follow the warnings outlined on the label pictured below. This label is also located on the water heater near the thermostat access panel.

⚠ DANGER

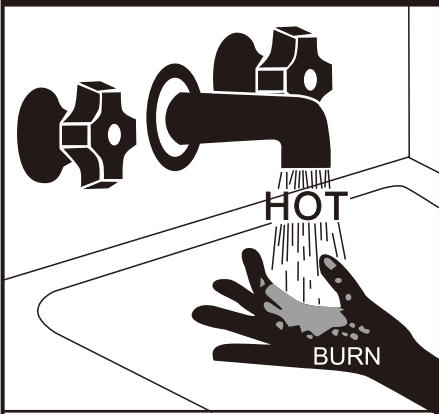

Water temperature over 125°F can cause severe burns instantly or death from scalds.

Children, disabled and elderly are at highest risk of being scalded.

See instruction manual before setting temperature at water heater

Feel water temperature with hand before bathing or showering.

Temperature limiting valves or mixing valves are recommended for use.

Time/Temperature Relationship in Scalds

Temperature	Time To Produce a Serious Burn
120°F	More than 5 minutes
125°F	1½ to 2 minutes
130°F	About 30 seconds
135°F	About 10 seconds
140°F	Less than 5 seconds
145°F	Less than 3 seconds
150°F	About 1½ seconds
155°F	About 1 second

The chart shown above may be used as a guide in determining the proper water temperature for your home.



DANGER: Households with small children, disabled, or elderly persons may require a 120°F or lower thermostat setting to prevent contact with "HOT" water. The temperature of the water in the heater is regulated by the electronic control on the front of the water heater. To comply with safety regulations, the thermostat was set at 120°F before the water heater was shipped from the factory.

Please consult Section 10 to learn more about setting your heaters temperature. Touch "UP" for higher temperature (up to 131F) or touch "DOWN" for cooler temperature (as low as 71F) will be displayed on the screen.

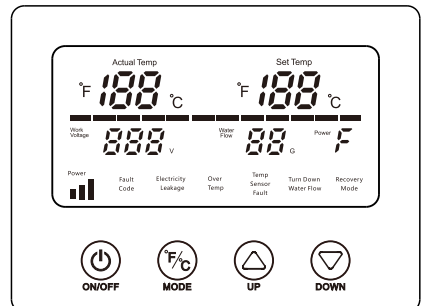

Notice: Mixing valves are recommended for reducing point of use water temperature by mixing hot and cold water in branch water lines. It is recommended that a mixing valve complying with the Standard for Temperature Actuated Mixing Valves for Hot Water Distribution Systems, ASSE 1017 be installed.

ABOUT YOUR TANKLESS WATER HEATER

Congratulations on the purchase of your Electric Tankless Water Heater! You have purchased the most technologically-advanced electric tankless water heater on the market today.

Your new electric tankless water heater features advanced water flow rate and temperature sensors designed to modulate power to the heating elements to maintain a precise user-selected output water temperature between 77° F and 131° F (subject to incoming water temperature and power of the selected model).

To get the best performance and energy savings from your electric tankless water heater, it is important that it be installed in accordance with our instructions and the electrical and plumbing codes applicable to your area, and that you read this manual thoroughly for important operating instructions and tips.

If you have questions at any time, please contact us directly at:

ECOPRO 55 W 116TH ST SUITE 116 New York NY 10026 TEL +1 646 825 1276
ECOPRONY@GMAIL.COM

CONTENTS

1. BEFORE INSTALLATION
2. SELECTING A LOCATION TO INSTALL
3. MOUNTING YOUR WATER HEATER
4. PLUMBING INSTALLATION
5. ELECTRICAL INSTALLATION
6. SIZING GUIDE
7. GENERAL OPERATING INSTRUCTIONS
8. MAINTENANCE
9. TROUBLE SHOOTING GUIDE
10. USER INTERFACE

1- BEFORE INSTALLATION

PLEASE READ THESE INSTRUCTIONS THOROUGHLY AND COMPLETELY PRIOR TO INSTALLATION & USE. FAILURE TO FOLLOW INSTRUCTIONS COULD CAUSE PROPERTY DAMAGE, SERIOUS PERSONAL INJURY, OR DEATH.

By installing this product, you acknowledge the terms of the manufacturer's warranty. Once the heater is installed, do not return product to the place of purchase. If you have any questions regarding the warranty or product return policies, please contact ECOPRO at +1 6468251276.

Inspect all components. The contents of your box should include one of the following units:

- E11
- E13
- E18
- E27

4- PLUMBING INSTALLATION

Please follow all plumbing instructions carefully. We recommend that this product be installed by a licensed and qualified plumber in accordance with all applicable national, state, provincial, and local plumbing codes.

Installation Instructions

STEP 1: Connect the HOT WATER line to the water heater OUTLET located on the left side of the heater when facing unit. Connect the COLD WATER line to the water heater marked INLET on the right side when facing unit.

STEP 2: After tightening both fittings at the water heater, open several hot water faucets and allow water to run through the water heater for at least 2 to 3 minutes. This process purges all the air from the water lines and MUST be performed prior to turning on the power at the unit. FAILURE TO FOLLOW THIS STEP CAN CAUSE PERMANENT DAMAGE TO THE HEATING ELEMENTS. If any maintenance is performed on the water heater or the home's plumbing system that may introduce air into the plumbing pipes, it is important to turn the power off to the water heater and purge the air out of the lines before allowing the unit to power up.

STEP 3: Carefully inspect all connections, unions, and the pressure relief valve (if installed) for leaks.

IMPORTANT NOTES:

1. Do not solder any pipes with unit connected to pipes – heat from soldering may damage the flow sensor. Doing so will void the warranty.
2. This automatic tankless water heater is equipped with both computer-controlled and electro-mechanical auto resetting thermostat switches for high-limited temperature protection. Since this product does not use a storage tank, the use of a temperature pressure relief valve (T&P) is not required for most installations. UL Standard 499 does NOT require that a pressure relief valve be used. However, a T&P valve may be required to meet installation codes in your area. If one is required, install the pressure relief valve in accordance with local codes and ensure that it operates correctly and that air is purged from the valve prior to installing the water heater. When connecting to Flex or High Temperature CPVC pipe, we recommend that a T&P valve be used for added safety.
Please note: Installations in the Commonwealth of Massachusetts and State of Kentucky require a pressure relief valve. Please check your local installation codes for any special requirements.
3. The maximum operating water pressure is 150 PSI. If the water pressure is higher, a pressure reducing valve must be installed on the main incoming water supply line prior to installing the electric tankless water heater.
4. Flexible water heater hoses are recommended to be used with your water heater as part of the installation. When connecting the inlet water pipe to the unit, make sure to use a wrench to hold the unit's connection, and another wrench to tighten, so that the flow sensor on the unit will not be loosened or damaged. Serious internal damage to the water heater can occur if the inlet or outlet connections are over tightened or if solder connections were made.
5. We recommend that a manual shut-off valve (ball valve) is installed on the inlet and outlet of the water heater so that there is a convenient shut-off point available in the event that future maintenance or servicing is required. It is extremely important to flush the lines to eliminate all plumbing paste or residue in the lines caused by any welding or soldering before connecting pipes to the water heater.

We recommend that all the water pipes or hoses within 3 feet of the inlet and outlet connections be rated for high temperature applications with a 150°F minimum.

5- ELECTRICAL INSTALLATION

ECOPRO recommends that this product be installed by a licensed and qualified electrician in accordance with all applicable national, state, provincial, and local electrical codes. As with all electrical appliances, under no circumstances should you attempt to install, repair or disassemble this water heater without first shutting off all power to the unit directly at the fuse or breaker box. **Make sure to shut off all breakers. SERIOUS BODILY INJURY OR DEATH COULD OCCUR IF YOU IGNORE THIS WARNING.**

All wiring (wire gauge) and circuit protection (breakers) must comply with the U.S. National Electrical Code (NEC) in the USA, or the Canadian Electrical Code (CEC) in Canada. Failure to do so could result in property damage and/or personal injury, and void your warranty. Note: The Canadian Electrical Code generally requires that all supply wires and corresponding circuit protection used for domestic hot water heating and hydronic heating applications be sized to a minimum of 125% of the maximum current rating of the heater (see model specifications below for details).

Before installing this product, ensure that the home has sufficient electrical power available to handle the maximum amperage load of the applicable model.

IMPORTANT NOTES:

Model E11 and E13 require 1 set of wire and ground (see wiring diagram)

Model E18 requires 2 sets of wire and ground (see wiring diagram)

Model E27 require 3 sets of wire and ground (see wiring diagram)

Please see electrical specifications by model and wiring diagram on the next page for additional electrical information.

Each set of wires must be connected to its own individual double pole breaker.

Installation Instructions

STEP 1: Take each wire pair and connect them to one breaker (see wiring diagram). Make sure that each breaker is connected with one black wire and one red wire

STEP 2: Using a suitable wire gauge that meets all applicable electrical codes for the size of the breakers used, run the correct sets of wire from the home's main breaker panel to the tankless water heater.

STEP 3: A separate ground conductor for each incoming circuit is required.

STEP 4: DOUBLE CHECK the electrical connections to make sure they are correct and that all wire connections are tight and secure. Also confirm that the correct breaker size and wire gauge has been used and confirm that the unit has been connected to a ground in accordance with applicable codes.

STEP 5: Confirm that all the air has been purged from the water lines prior to turning on power to the unit. Refer to STEP 2 in the plumbing installation section.

CAUTION: Ensure that you have made the correct connections. You must follow the wire connection as shown to ensure proper operation of the unit. If you mix up one set of wires with another, the unit will not operate correctly even though it turns on and otherwise appears to function properly.

The water heater is now installed and ready to use! Follow the General Operating Instructions to complete the setup. We highly recommend that this is done with the homeowner present.

Electrical Specifications by Model

MODELS	E11	E13	E18	E27
VOLTAGE	240 V	240 V	240 V	240 V
MAX kW	11 kW	13 kW	18 kW	27 kW
MAX AMPERAGE DRAW	46 AMPS	54 AMPS	75 AMPS	112.5 AMPS
REQUIRED BREAKERS	1 X 60 AMP	1 X 60 AMP	2 X 40 AMP	3 x 40 AMP
REQUIRED WIRE GAUGE	1 x 6 AWG	1 x 6 AWG	2 X 8 AWG	3 x 8 AWG

Wiring Diagram

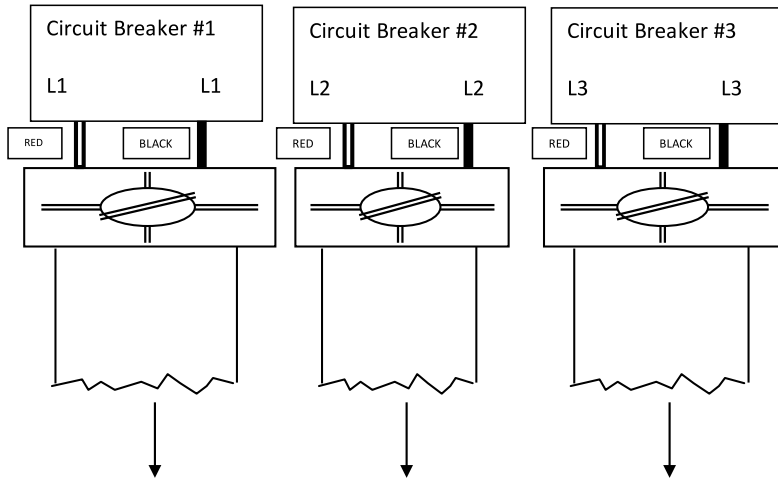

E11 – E13
requires 1 breaker and
1 set of wires

E18 requires 2 sets of breakers and wires

E27 require 3 sets of breakers and wires

6- SIZING GUIDE

Please use the chart below to see how many gallons per minute your tankless water heater can produce with your incoming water temperature. The gallons per minute is calculated assuming 105°F outlet temperature.

Incoming Water Temperature	E11	E13	E18	E27
40°F	1.2	1.4	1.9	2.8
45°F	1.3	1.5	2.0	3.1
50°F	1.4	1.6	2.2	3.4
55°F	1.6	1.8	2.5	3.7
60°F	1.7	2.0	2.7	4.1
65°F	2.0	2.2	3.1	4.6
70°F	2.2	2.5	3.5	5.3
75°F	2.6	3.0	4.1	6.1
80°F	3.0	3.6	4.9	7.4

(Gallons per Minute)

FLOW REGULATOR – OPTIONAL

To ensure the optimal temperature output and overall performance of your tankless water heater you may require a flow regulator. These flow regulators are installed on the outlet connection of your tankless water heater and limit the maximum volume coming out of your unit to a specified flow rate to prevent the exit temperature from becoming too cool. To learn more about flow regulators or find out how to purchase one for your tankless water heater contact us at 1-646-825-1276.

Steps for Choosing a Flow Regulator

1. Find your model in the chart on the left
2. Choose the column with the inlet water temperature closest to your geographical location
3. Take the GPM or gallons per minute you find and match it with the corresponding flow regulator on the right

	Inlet Water Temperature			
	40°F	50°F	60°F	70°F
E11	1.0	1.0	1.5	2.0
E13	1.0	1.0	1.5	2.0
E18	2.0	2.0	2.0	3.0
E27	2.0	3.0	4.0	5.0

ECOPRO Part Number	Maximum Flow Rate	Connection Size
E IFR 1-2	1.0 GPM	1/2" Compression
	1.5 GPM	1/2" Compression
	2.0 GPM	1/2" Compression
E IFR 3-4	2.0 GPM	3/4" NPT
	3.0 GPM	3/4" NPT
	4.0 GPM	3/4" NPT
	5.0 GPM	3/4" NPT

*Selection based on inlet temperature above and outlet temperature of 105°F

7- GENERAL OPERATING INSTRUCTIONS

Operating your new tankless water heater is similar to using any traditional water heating system. However, it is very important that you carefully read all of the setup procedures and operating instructions and tips to ensure the maximum performance and energy savings from your new water heater. We recommend that all members of the household read these General Operating Instructions.

How your new water heater works: Your tankless water heater does not store hot water like a conventional tank-type water heater. It contains high powered heating elements that are capable of heating water on-demand. As soon as you turn on a hot water faucet, a sophisticated flow sensor recognizes that you have turned on the water. This sensor measures flow rate while another sensor measures the incoming water temperature. This information is transmitted continually to the computer logic controls which decide how much power to send to the heating elements to heat the water to your desired temperature. Once the water faucet is turned off your water heater will turn off as well.

8- MAINTENANCE

To ensure maximum performance of your water heater and to reduce the risk of a water leak, we recommend the following maintenance:

Inspect the connections on the inlet and outlet of the water heater at least on an annual basis for any signs of damage or failure. Any signs of damage, cracks, leakage or weakness should be addressed. Take care not to over tighten the connections. Serious internal damage to your water heater can occur if you over tighten the water heater connections at the unit.

IMPORTANT NOTES:

As with all electrical appliances, under no circumstances should you attempt to install, repair or disassemble this water heater without first shutting off all power to the unit directly at the fuse or breaker box. **SERIOUS BODILY INJURY OR DEATH COULD OCCUR IF YOU IGNORE THIS WARNING.**

When any maintenance is performed on the water heater or the home's plumbing system that may introduce air into the plumbing pipes, it is important to turn the power off to the water heater and purge the air out of the lines before allowing the unit to power up. **FAILURE TO DO SO COULD CAUSE PERMANENT DAMAGE TO THE HEATING ELEMENT AND VOID YOUR WARRANTY.**

If you have a water supply with a high level of mineralization (hard water), you should increase the frequency of your maintenance.

9- TROUBLE SHOOTING GUIDE

Are you having problems with your water heater?

Please call or email our customer service and technical support team for any help you may need.

**ECOPRO
55 W 116TH ST
SUITE 116
New York NY 10026
TEL +1 646 825 1276
ECOPRONY@GMAIL.COM**

The following table represents some of the most common technical support questions we receive. Before calling us, please read thoroughly to see if your question or problem is addressed.

PROBLEM	POSSIBLE CAUSE	SOLUTION
Water heater is not heating at all (water is flowing but the unit is not heating - the outgoing water temperature is the same as the cold water supply) - the digital display does NOT light up.	No power or incorrect wiring.	Make sure the breakers at main electrical panel are ON. You may have a faulty breaker or unit may be wired incorrectly.
	Flow rate is too low / water pressure is too low.	Your water heater has an activation flow rate of approximately 0.3 GPM. If your water flow rate is less than this level, your unit will not activate. Increase the flow rate.
Water heater is not heating at all (water is flowing but the unit is not heating - the outgoing water temperature is the same as the cold water supply) The digital display DOES light up.	Internal part failure.	Please call us for technical assistance.
Water heater is heating, but the water temperature is not hot enough.	User temperature setting too low.	Turn up the temperature setting on the unit.
	Flow rate is too high.	Depending on your incoming water temperature and the power output of your model, your water flow rate may exceed the physical heating capacity of your water heater. Reduce the flow rate by installing an ECOPRO Flow Regulator. Use the chart in section 6 to find out which flow regulator works best for your particular model.
	Crossed wires.	If it's a new installation, have your electrician double check the wiring. Is possible that the wiring is incorrect.
	Voltage less than 240 volts.	The heating elements on your water heater are design for 240 volts. When used with a lower voltage, they produce less heating power. You may need to upgrade to a larger model.
	Mixing too much cold water.	You do not need to mix as much cold water with your tankless water heater compared to when you use a conventional water heater. You may also have an anti-scald feature on your faucet that is mixing cold water. These types of faucets can usually be adjusted to reduce the amount of cold water mixed.
The water temperature at the faucet is less than the temperature setting of my water heater.	Voltage less than 240 volts.	The computer chips in your tankless water heater are programmed with the expectation that your incoming line voltage is 240 volts. If you have less than 240 volts, it may affect the reading on your water heater's digital display and cause it to read slightly higher than the actual output temperature. To compensate for this, increase the setting on your water heater if you need / want hotter water.
	Anti-Scald pressure/balancing valve or tempering valve.	Your faucet may have an anti-scald feature or a tempering valve that automatically mixes cold water even when you turn your control lever or handle to full hot. These devices are usually adjustable so you can turn off the cold mix completely. You can compensate for this by increasing the setting on your water heater if you need/want hotter water.
	Thermal loss due to long pipe run	As the hot water from the heater runs through the hot water delivery system to your faucet, some heat will be lost especially if it has long distance to travel or the pipes are cold. This is normal. You can compensate for this by increasing the setting on your water heater if you need/want hotter water.

10- USER INTERFACE

Power

- Press Power button  on the unit to turn ON/OFF the appliance. When the unit is working, LED lights show "Actual Temp", "Set Temp", "Work voltage", "Water flow" and "Power". When we turn off the water supply or not enough water pressure, only the "Actual Temp" and "Set Temp" is displayed.

C/F Conversion

- Press F/C to change the temperature display between Fahrenheit

Temperature Control

- Touch "UP" for higher temperature (up to 131F)
- Touch "DOWN" for cooler temperature (as low as 71F)
- You can set or adjust the temperature at any time between 71° F– 131° F (25° C– 55° C). The temperature can be changed to your desired setting.

CAUTION: Removing the cover to change the temperature set point exposes electrical shock and burn hazards, which can cause INJURY or DEATH. Adjustment should only be done by a licensed plumber or electrician.

DANGER: Hotter water increases the potential for Hot Water SCALDS.

E11-E13-E18-E27

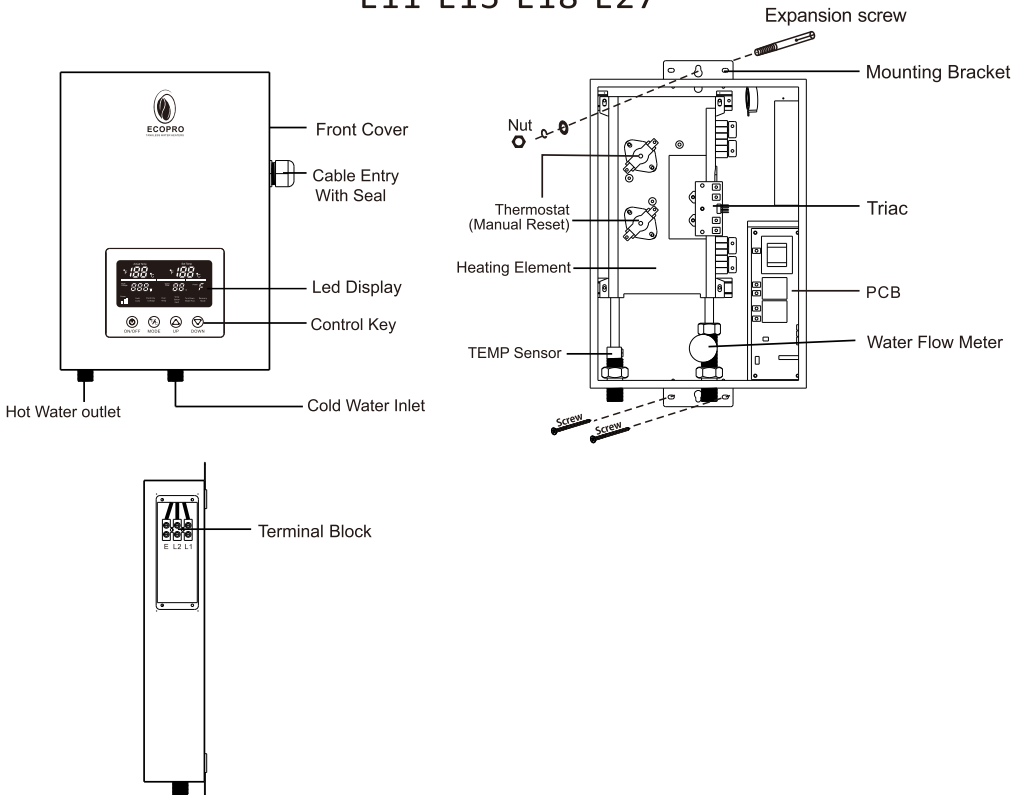

ECOPRO

MANUFACTURERS WARRANTY MAINLAND USA and CANADA- LIMITED LIFETIME OUTSIDE MAINLAND USA – 5 YEARS

1. PRODUCT WARRANTY: ECOPRO Products warrants to the original purchaser at the original address or the authorized transferee of such purchaser (collectively, the “Buyer”) ECOPRO Tankless Water Heater and its components to be free from defects in materials and workmanship, under normal use and service from the date of installation, provided that the Product is installed within thirty (30) days from date of receipt and installed by a licensed electrician and plumber (specific proof required) and maintained in accordance with Products written instructions. The Product Warranty will be in effect upon receipt of the Warranty Registration by ECOPRO offices. The Warranty Registration is included in the Operating and Maintenance Manual supplied with each new product and must be fully completed and submitted via fax, mail or website within (30) days of receipt of Product. Incomplete Warranty Registrations will not be accepted. Product Warranties are void without receipt of Warranty Registration within (30) days of receipt of Product.

SUCH WARRANTIES DO NOT COVER:

- Product failure caused by liming, sediment buildup, chemical corrosion, chlorine/chloride corrosion, or freezing.
- Product failure caused by the failure to remove air from system prior to or during operation.
- Product misuse, tampering or misapplication, accidental damage, improper installation or the application of improper voltage.
- Costs incurred for shipping, delivery, handling and/or administrative charges.
- Labor charges of any kind.

THE FOREGOING WARRANTIES ARE EXCLUSIVE AND IN LIEU OF ANY OTHER WARRANTY, EXPRESSED OR IMPLIED, INCLUDING BUT NOT LIMITED TO ANY IMPLIED WARRANTY OF MERCHANTABILITY OR FITNESS FOR A PARTICULAR PURPOSE OR PATENT OR OTHER INTELLECTUAL PROPERTY RIGHT INFRINGEMENT.

2. LIMITATION OF REMEDIES AND DAMAGES: ECOPRO Products liability and Buyer’s exclusive remedy hereunder will be limited solely to repair or replacement of Product under Warranty by ECOPRO Service Center with respect to any claim made within the applicable Warranty. ECOPRO Products reserves the right to accept or reject any such claim in whole or in part. ECOPRO Products will not accept the return of any product without prior written approval from ECOPRO Center and the issuance of a Return Merchandise Authorization Number clearly marked on the outside packaging of the return shipment.

PRODUCTS WILL NOT BE LIABLE, UNDER ANY CIRCUMSTANCES, FOR CONSEQUENTIAL OR INCIDENTAL DAMAGES, INCLUDING BUT NOT LIMITED TO LABOR COSTS OR LOST PROFITS RESULTING FROM THE USE OF (OR INABILITY TO USE) THE PRODUCTS OR FROM THE PRODUCTS BEING INCORPORATED IN OR BECOMING A COMPONENT OF ANY OTHER PRODUCT OR GOODS.

3. WARRANTY REGISTRATION: To be covered under the ECOPRO Products Manufacturer’s Limited Lifetime Warranty Buyer must register product within thirty (30) calendar days of receipt of Product using the Warranty Registration Card included with the Product, this Warranty may be submitted via mail to ECOPRO 55 W 116TH ST SUITE 116 New York NY 10026 TEL +1 6468251276. THIS IS A LIMITED LIFETIME MANUFACTURER’S WARRANTY THAT CONVEYS BENEFITS TO THE ORIGINAL PURCHASERS, SUBJECT TO THE TERMS AND CONDITIONS SET FORTH HEREIN. Keep Product documents in a safe and secure location. Buyer obligation under the terms of purchase and sale require that Warranty Registration must be returned within the prescribed timeframe (within 30 calendar days) and retain all proof of purchase, installer receipts for Warranty in order to protect Buyer’s rights and obtain Manufacturer’s Limited Lifetime Warranty benefits. The Warranty resides with the Buyer with proof of purchase; not simply with an individual in possession of a Product. If the Product is to be installed in new construction at a date later than 30 days from the date of receipt, send further information in advance of thirty (30) day deadline when known so we may update your Warranty record.

4. FURTHER LIMITATIONS AND EXCLUSIONS AFFECTING YOUR WARRANTY: This warranty is void if the Product is not installed in accordance with relevant, local electrical and plumbing codes and in accordance with the installation

instructions specified by the manufacturer. Local codes will override manufacturer's instructions at the time of installation and if additional installation parts are required, the costs will be the responsibility of Buyer. Above ground level installations must be protected with drip pans and drains just as the codes call for protective requirements used in regular hot water tank installations. Buyer hereby accepts the entire responsibility for ascertaining whether they have sufficient electrical power at their residence to operate our Electric Tankless Water Heaters as indicated in our specifications which are readily available at our website , in our brochures and contained in the shipping box for installers to read before installations. If, within (30) days of purchase and prior to installation, the Buyer finds that the purchased unit is not suitable for their demands Buyer must return the unit to the ECOPRO office. Buyer is responsible for any charges that may be incurred to complete the return. A Buyer is eligible for a full refund or credit ONLY if the returned unit is received by ECOPRO within thirty (30) calendar days of receipt AND has been inspected by ECOPRO and found to be in the same condition as when purchased. Only when these two conditions are met will a Buyer receive a refund or replacement unit. ECOPRO Products will not accept the return of any product without prior written approval from Products and the issuance of a Return Merchandise Authorization Number clearly marked on the outside packaging of the return shipment.

AFTER (30) CALENDAR DAYS FROM RECEIPT OF PRODUCT THERE WILL BE NO RETURNS OR WARRANTY WITHOUT RECEIPT OF WARRANTY REGISTRATION BY ECOPRO US. BUYER ACCEPTS ALL SALES AS FINAL. ANY ALTERATION TO THE PRODUCT VOIDS ALL WARRANTIES. ECOPRO PRODUCTS IS NOT RESPONSIBLE FOR ANY OTHER CHARGE OR EXPENSE INCURRED, OTHER THAN THE ORIGINAL PURCHASE PRICE OF THE PRODUCT. ECOPRO PRODUCTS shall not be liable for consequential, special, incidental or contingent expenses or damages arising directly or indirectly from any defect in or of the Product; nor will ECOPRO Products be liable for any water damage arising directly or indirectly from the use of the Product or from the failure of or defect in any component part or connecting plumbing. ECOPRO Products and Buyer agree to the above terms in their entirety and accept all sales as final without recourse to a credit card company or other financial institution and hereby agree to stipulations and specifications defined within Manufacturer's Limited Lifetime Warranty.

5. Warranty Procedure for service: Have a licensed electrician determine the exact issue that requires repair. Please note that technical support is available for qualified technicians only (licensed electricians and/or plumbers). Technical support that involves potentially dangerous electrical conditions is not available to unqualified persons. When contacting ECOPRO , please be sure that the technician has a copy of the original Warranty Registration and has reviewed the "Homeowners and Installation Manual" that was supplied with the Product. ECOPRO Technical Assistance, at its sole discretion, will determine the best method for repair. Methods of repair include, but are not limited to, replacement of specific part of Product or replacement of whole unit. If a whole unit requires replacement under the terms of this Manufacturer's Warranty, the original unit must be returned to the ECOPRO office. Buyer must secure the cost of return delivery and replacement unit with a valid U.S. credit card. Credit Card Authorization Forms are available upon request. If the replaced unit arrives at the ECOPRO office within ten (10) calendar days of shipment of new unit and is found to comply within the specifications of this Manufacturer's Warranty then the credit card will not be charged, otherwise, Buyer will be charged amount of replacement unit and shipment cost as agreed upon within Credit Card Authorization Form. If ECOPRO Technical Assistance determines a component requires repair or replacement under the terms of this Manufacturer's Limited Lifetime Warranty, the part will be shipped via standard ground delivery. **If faster shipping service is desired, the Buyer must select and pay for same.**

ANY QUESTIONS REGARDING OUR FIVE (5) YEAR WARRANTY SHOULD BE DIRECTED TO OUR SERVICE CENTER BY CALLING TOLL FREE +1 6468251276 BETWEEN 8:00 AM and 5:00 PM MONDAY thru FRIDAY EASTERN TIME. NO RETURN WILL BE ACCEPTED BY ECOPRO WITHOUT PRIOR APPROVAL AND THE ISSUANCE OF RETURN MERCHANDISE AUTHORIZATION NUMBER CLEARLY MARKED ON THE EXTERIOR OF PACKAGING.

ECOPRO 55 W 116TH ST SUITE 116 New York NY 10026 TEL +1 646 825 1276
ECOPRONY@GMAIL.COM



ECOPRO

TANKLESS WATER HEATERS

ECOPRO

55 W 116TH ST

SUITE 116

New York NY 10026

TEL +1 646 825 1276

ECOPRONY@GMAIL.COM